

Crowded Skies

US Air Force and Air National Guard Flying Activities In Central South Carolina

Mid-Air Collision Avoidance Program



Published by:

20th Fighter Wing, Shaw Air Force Base, SC

169 Fighter Wing, McEntire Joint National Guard Base, SC
and

437 Airlift Wing, Joint Base Charleston, SC



DEPARTMENT OF THE AIR FORCE
20th Fighter Wing (ACC)
Shaw Air Force Base, South Carolina

3 Feb 14

To: All Flyers Who Share the South Carolina Skies

More and more of us have discovered the joy of flying, and our shared airspace is subsequently becoming increasingly crowded with military, general aviation, and business aircraft. This ever-increasing mix of high- and low-performance aircraft raises the potential for a mid-air collision.

One way to lessen the danger posed by the crowded skies is for us to give civil aviators a “heads-up” about the types of flying we do in the Air Force to accomplish our mission of national defense. This booklet was developed jointly by Shaw Air Force Base, Joint Base Charleston, and McEntire Joint National Guard Base personnel. We believe this booklet will give you a basic understanding of military operations and Air Traffic Control services available in our area.

Our objective with this booklet is to promote a mutual understanding with our neighbors in the South Carolina skies. If you have questions about our operations, please do not hesitate to call the phone numbers listed on the back cover. The people in these offices will be glad to discuss your concerns, and will do their best to provide a satisfactory answer to your questions.

We in the business of military aviation are happy to work with you, and do our part to keep the South Carolina skies safe for everyone!

Chief, Flight Safety
Shaw Air Force Base, South Carolina

Atch- Booklet

SECTION 1 ----- SHAW AIR FORCE BASE LOCAL AREA

Shaw Air Force Base (SSC) is located near the city of Sumter in central South Carolina, approximately 35 miles east of Columbia. **McEntire Joint National Guard Base (MMT)** is situated between Columbia and Shaw Air Force Base (AFB). **Joint Base Charleston (CHS)** is located on the coast of South Carolina about 75 miles to the south/southeast of Shaw AFB.

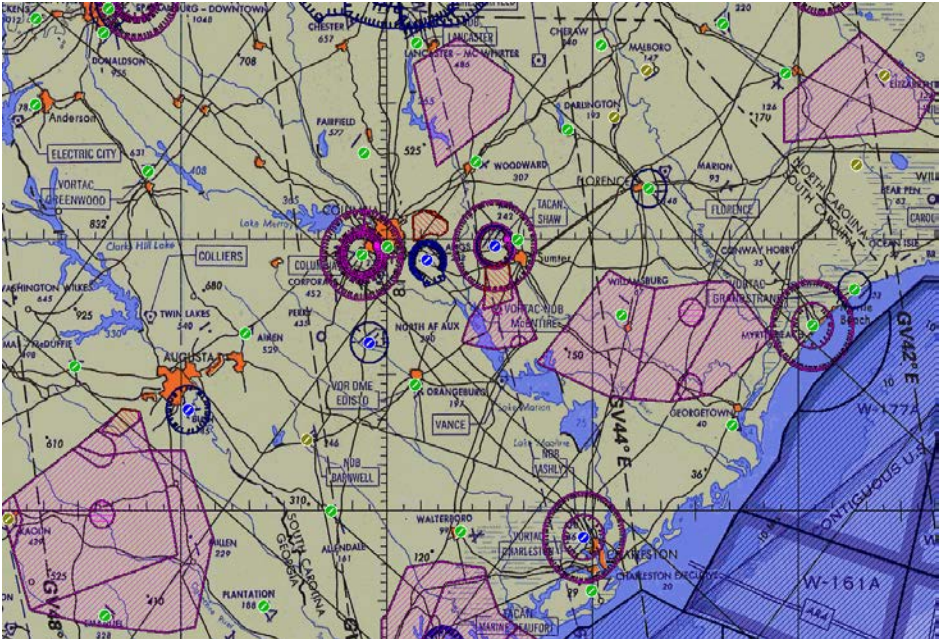

Figure 1: Local Flying Area

Shaw Air Force Base is home to three squadrons of F-16 fighter jets, while McEntire Joint National Guard Base has one squadron of F-16s. Joint Base Charleston is home to the C-17 cargo aircraft.

SHAW AFB DEPARTURE PROCEDURES:

IFR Departure Procedures: Shaw AFB jets usually depart via runway heading (either 040 or 220) and climb to 3,000 feet MSL or higher before turning on course. F-16s are normally on an IFR flight plan and climb out at around 350 knots in excess of 6,000 feet per minute; they will generally be flying as a flight of two or more. They will be on an easterly heading if going to the Gamecock B/C/D MOAs or the warning areas off the coast, or a southwesterly heading if flying to the Bulldog MOAs southwest of Augusta, GA. The Gamecock C and D MOAs, the Bulldog MOAs, W-161, and W-177 are the primary training areas for the F-16s of Shaw AFB and McEntire Joint National Guard Base (JNGB). We encourage you to keep your “head on a swivel” and call Shaw RAPCON for traffic advisories in this area.

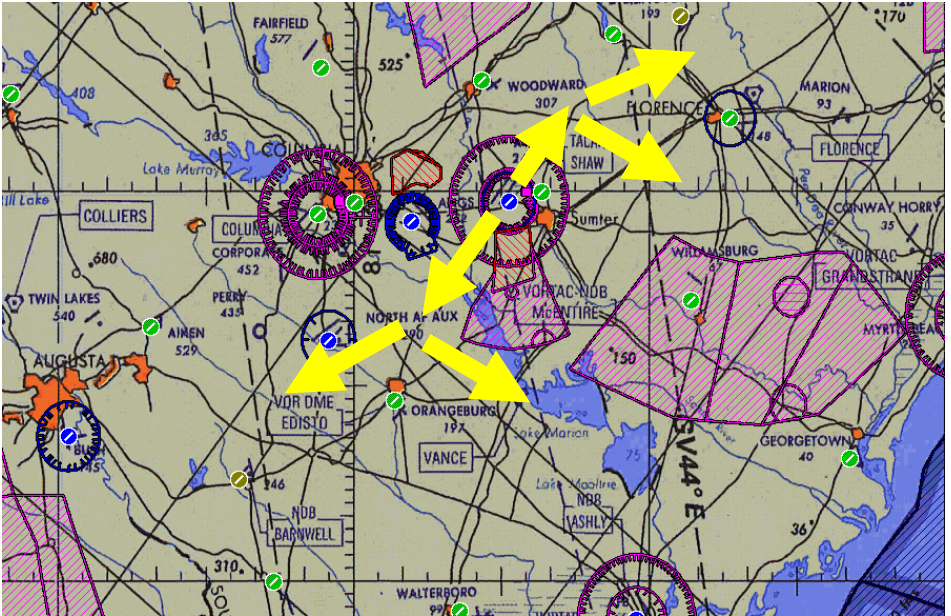

Figure 2: Shaw AFB IFR Departures

VFR Departure Procedures:

1. **Stacks Departure:** F-16s occasionally depart Shaw AFB via the “Stacks” Departure, in which they cross the departure end of runway 22 at or below 1,000 feet MSL and climb VFR to 9,500 feet MSL until reaching the smoke stacks (a VFR reporting point) on the SSC 225 radial at 12 NM.
2. **Sumter Departure:** F-16s departing on this VFR procedure normally take-off on runway 22L and cross the departure end of the runway at or below 1,000 feet MSL, then turn left heading 070 within 1 NM and climb to 3,000 feet MSL as a two-ship, or 6,000 feet MSL as a flight of three or more. Pilots maintain VFR until north of Shaw’s 120 radial at which time they pick up their IFR clearance and proceed on course. (See Figure 3 for the Stacks and Sumter Departures).

Stacks and Sumter Departure

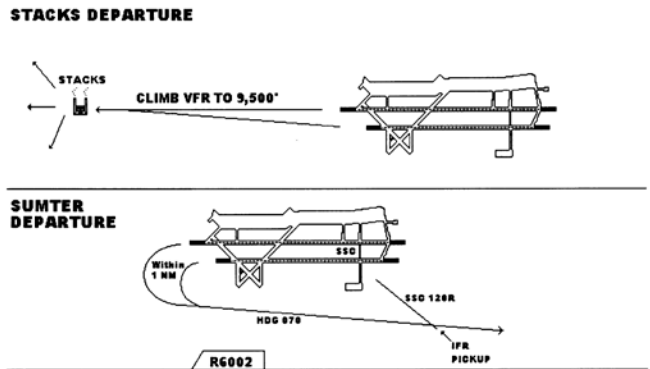
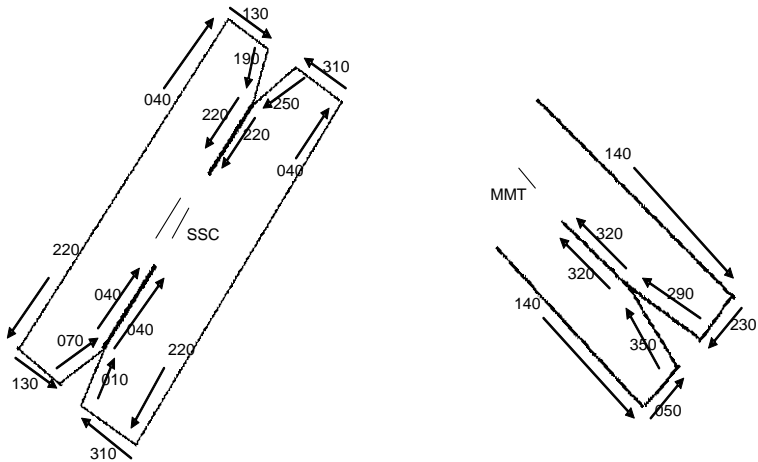

Figure 3: Stacks and Sumter Departures

SHAW AFB ARRIVAL PROCEDURES:

IFR Arrival Procedures: F-16s arriving at Shaw will normally descend from en route altitudes to be at 2,000 feet MSL or 3,000 feet MSL in the local radar traffic pattern (see Figure 4), which is run on both the east and west sides of the airport. Again, they may be in formation of two or more aircraft.

RADAR Traffic Pattern



4.2. Shaw Traffic Patterns. Standard left turns required for Runway 04L/22L and right turns for Runway 04R/22R.

4.2.1. Helicopter: 800 feet MSL.

4.2.2. Rectangular (Conventional): 1,500 feet MSL.

4.2.3. Overhead: 2,000 feet MSL.

4.2.4. Radar: 3,000 feet MSL.

4.2.5. SFO: 3,000 - 9,500 feet MSL.

4.2.6. The weather criteria for the Rectangular, Overhead, and Helicopter Patterns is 500' above the pattern altitude and 3 Statute Miles (SM) visibility. For SFOs the ceiling must be at least 1,000 feet above SFO entry altitude and 5 SM visibility. **Note:** Weather criteria is in Above Ground Level (AGL).

4.2.7. Low Closed Pattern. This pattern will normally be flown following an instrument approach and planned to a full stop. The intent is to allow a visual VFR pattern during IFR conditions to a non-instrument runway.

4.2.7.1. The Low Closed Pattern will normally be flown following an instrument approach and planned to a full stop and must be approved by Tower. The intent is to allow a VFR pattern during low ceiling/cloud conditions to a non-instrument runway. Pilots —breaking-out from low closed must return to radar for sequencing back into Shaw AFB radar pattern unless the VFR pattern is open. Tower will specify direction of turns and will use standard overhead terminology except for specifying —low closed. Tower will not approve low closed patterns while overhead patterns are being conducted. When the low closed pattern is in use, the rectangular and overhead patterns shall not be used.

Reference: SAFBI 11-250, paragraph 4.1

Figure 4: Shaw AFB Radar Traffic Pattern

VFR Arrival Procedures:

1. **Straight In:** A straight-in arrival to runway 04 or 22 will be at 1,500 feet MSL approximately 8 miles on final, descending to land.
2. **Ponds/Stacks Recovery:** Pilots may request vectors to the "initial" overhead pattern via two VFR reporting points: PONDS on the SSC 040 radial at 12 NM, or STACKS on the SSC 225 radial at 12 NM. They will cross these points at 2,500 feet MSL at 300 knots and descend to pattern altitude of 2,000 feet MSL at 5 mile final.
3. **Other VFR Entry Procedures:** There are several other VFR reporting points around Shaw AFB on both the east and west sides of the field which are used to enter the local traffic pattern (see Figures 5 & 6).

SAFB VFR Traffic Pattern

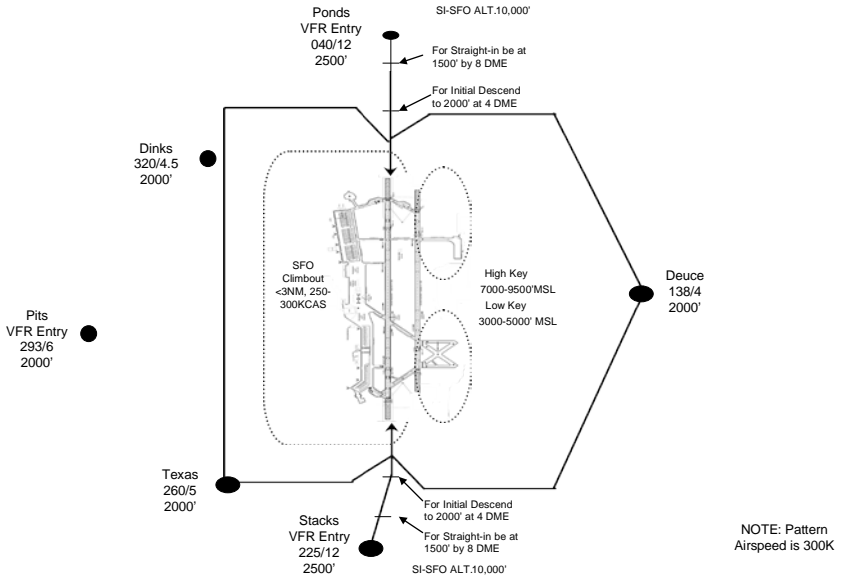

Figure 5: Shaw AFB VFR Traffic Pattern Drawing

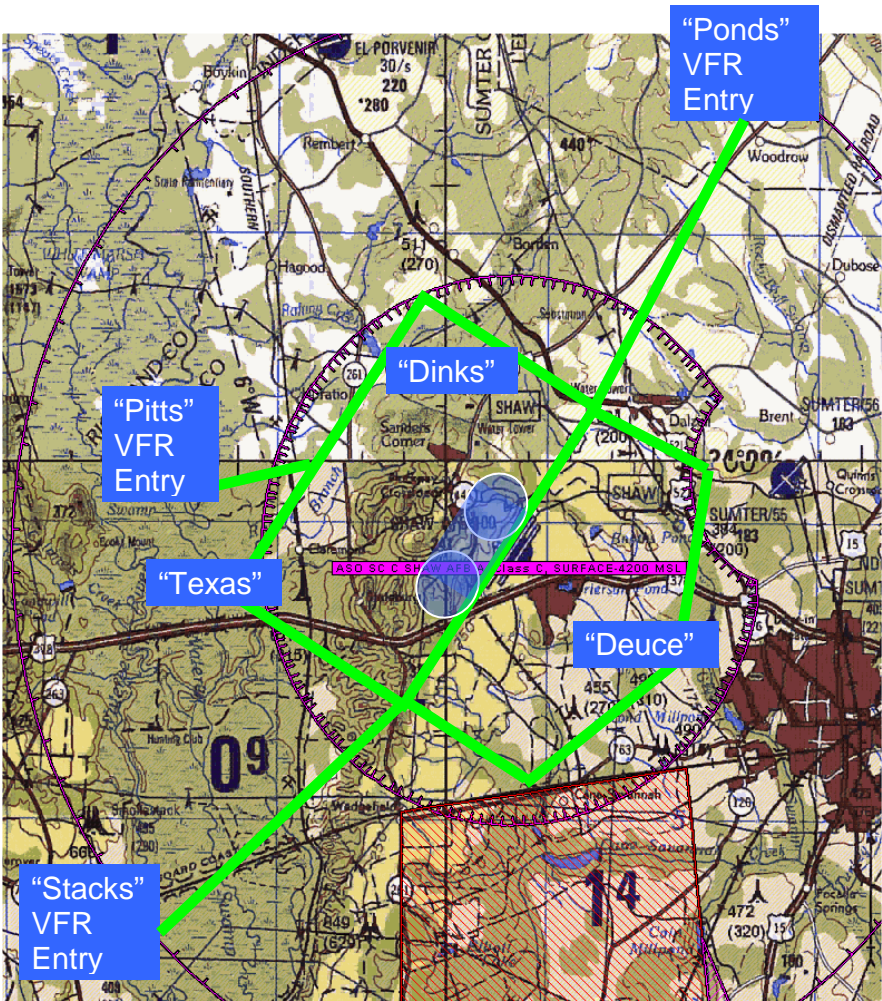
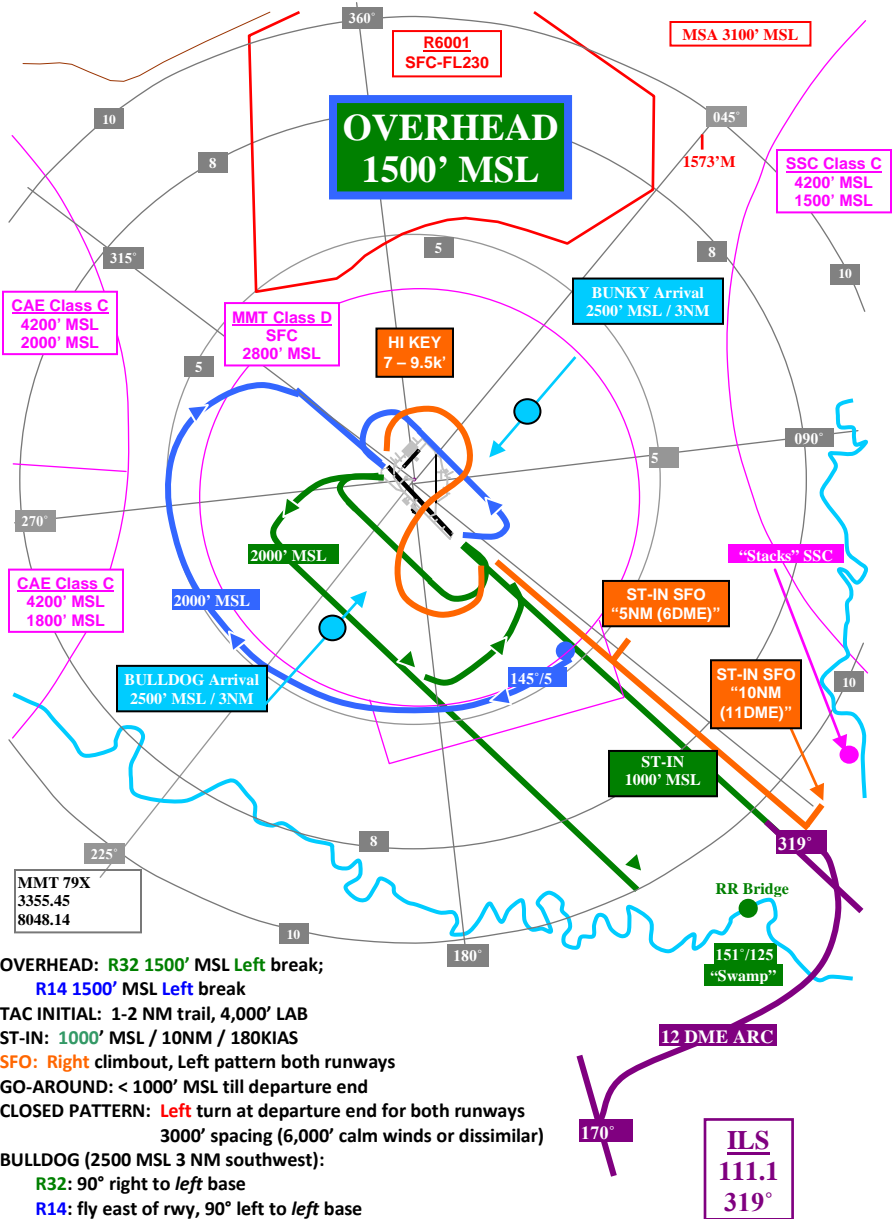

Figure 6: Shaw AFB VFR Traffic Pattern on Map

McEntire Joint National Guard Base TRAFFIC PATTERN:



OVERHEAD: R32 1500' MSL Left break;
 R14 1500' MSL Left break
TAC INITIAL: 1-2 NM trail, 4,000' LAB
ST-IN: 1000' MSL / 10NM / 180KIAS
SFO: Right climbout, Left pattern both runways
GO-AROUND: < 1000' MSL till departure end
CLOSED PATTERN: Left turn at departure end for both runways
 3000' spacing (6,000' calm winds or dissimilar)
BULLDOG (2500 MSL 3 NM southwest):
 R32: 90° right to left base
 R14: fly east of rwy, 90° left to left base
BUNKY (2500 MSL 3 NM northeast):
 R32: fly west of rwy, 90° left to left base
 R14: 90° right to left base

Figure 7: McEntire JNGB Traffic Pattern

Shaw RAPCON Terminal Airspace: Shaw Radar Approach Control (RAPCON) air traffic controllers are delegated the airspace from the surface to 10,000 feet MSL as depicted in Figure 8. Within this area Jacksonville Center controls the airspace above 10,000 feet MSL.

Shaw RAPCON Terminal Airspace
Surface to 10,000 feet MSL

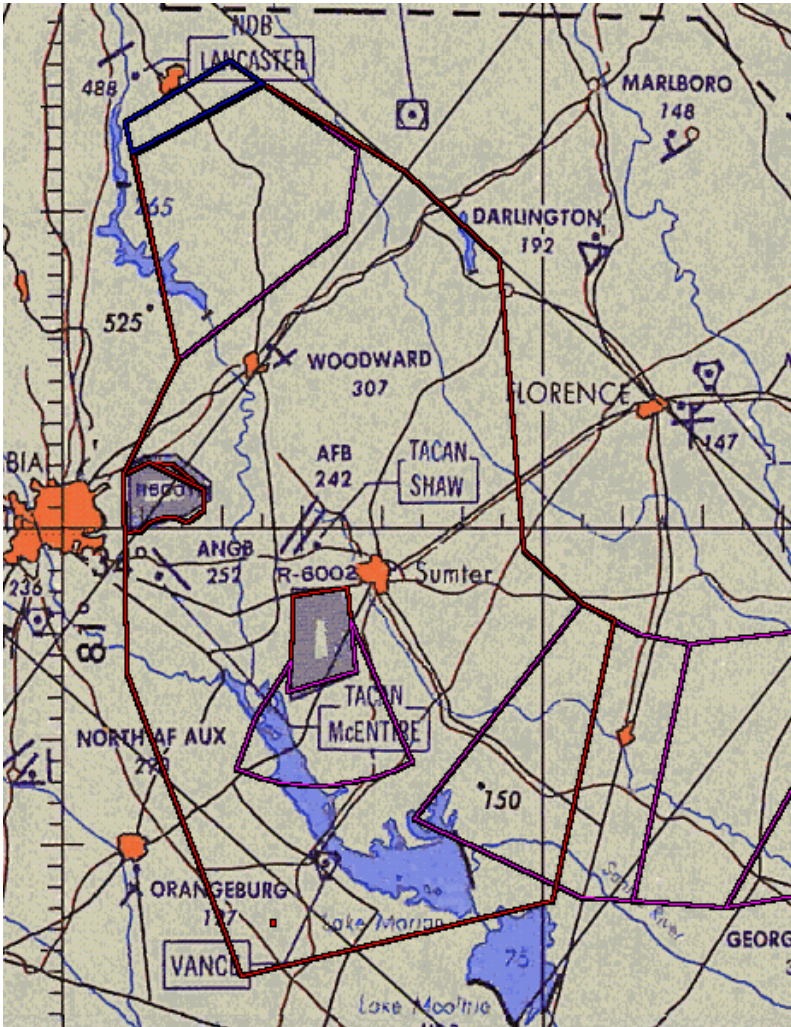

Figure 8: Shaw RAPCON Terminal Airspace

SECTION 2 ----- TYPES OF SPECIAL USE AIRSPACE

Background: Our national security depends heavily on the deterrent effect of our airborne military forces. That deterrent effect is predicated on our credible ability to accomplish the missions we're ordered to perform. These missions may include: intercepts, air-to-air combat, aerial refueling, ground troop support, and both high and low altitude navigation and bombing. To remain "top-notch" in these areas, we must rehearse our maneuvers and tactics. These rehearsals are done in the national airspace system which we share with you. A variety of routes and areas have been created in which military aviators sharpen these war-fighting skills. By identifying these areas we hope to increase the awareness and understanding of civil pilots flying in and around these areas.

Restricted Areas: You may be surprised to know what types of activities occur in restricted areas. These areas are most often used for weapons delivery practice - such as dropping bombs and flares, ground and aerial gunnery, illuminating targets with lasers, firing rockets, or firing from ground-based artillery. For everyone's safety, flights not participating in that particular activity are restricted from flying within these areas while the area is active. In central South Carolina, there are two primary restricted areas:

R6001: Fort Jackson range is just east of Columbia, SC, and operates almost continuously from the surface to 3,200 feet MSL. It also operates sporadically from the surface to 5,500 feet MSL, or as high as 23,000 feet MSL (FL230). (See Figure 9 on following page.)

R6002: Poinsett Weapons Range is located to the southwest of Sumter, SC, and usually operates intermittently Monday through Friday from 0600-2300, with occasional weekend activity. The inclusive altitudes vary from the surface to FL230 as required. This is a three part restricted area (A, B, and C) and the individual elements may be activated without regard to the others. The airspace may be transited when not in use by military aircraft. (See Figure 9 on following page.)

NOTE: Military aircraft waiting for clearance to enter R-6002 often hold VFR at the Rimini Bridge approximately 15 NM SW of Shaw AFB. They may hold at any VFR altitude.

For both of these restricted areas you can contact Shaw Radar Approach Control on 125.4 for traffic advisories and the current status.

Military Operations Areas (MOAs): These areas were established to segregate certain military activities such as air combat maneuvering, intercepts, and other aerobatics from non-participating IFR traffic. There are several MOAs near Shaw AFB where you may encounter military aircraft.

The **Gamecock MOAs** to the south and southeast of Shaw AFB include the following:

Gamecock B: 10,000 feet MSL up to FL180 (used only during exercises)

Gamecock C: 100 feet AGL up to 10,000 feet MSL

Gamecock D: 12,000 feet MSL up to FL180, with Air Traffic Control Assigned Airspace (ATCAA) up to FL220

Poinsett: 300 feet AGL up to 2,500 feet MSL

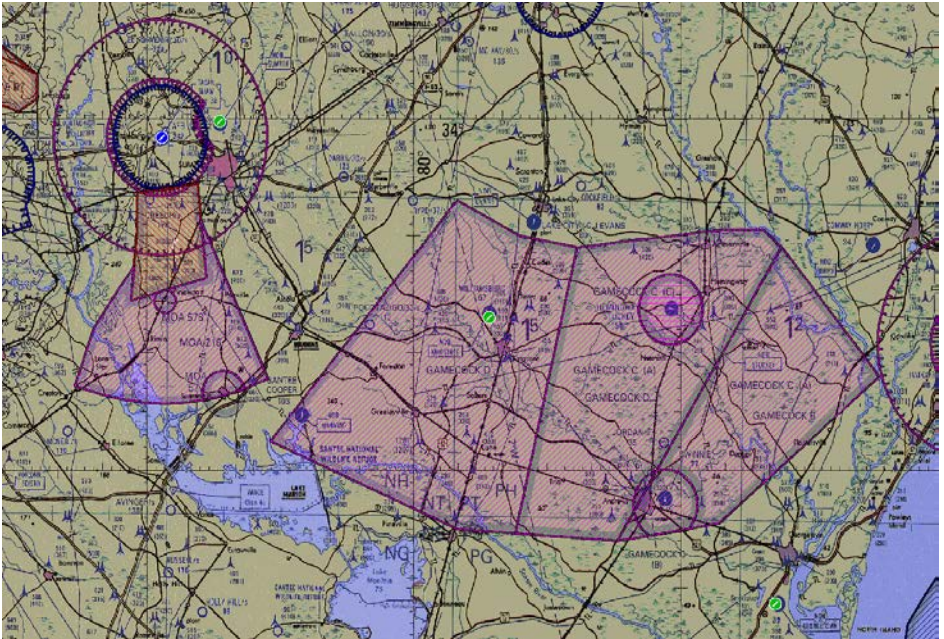

Figure 9: Gamecock and Poinsett MOAs

GAMECOCK B, C, D, and ROBROY MOAs: Gamecock Bravo, Charlie, Delta, and Robroy MOAs piece together at various altitudes as depicted below in God’s-eye (Figure 10) and grandstand (Figure 11) views. Gamecock Delta and Charlie MOAs cannot be used simultaneously due to the altitude gap from 10000-12000 feet MSL, which is used to route traffic.

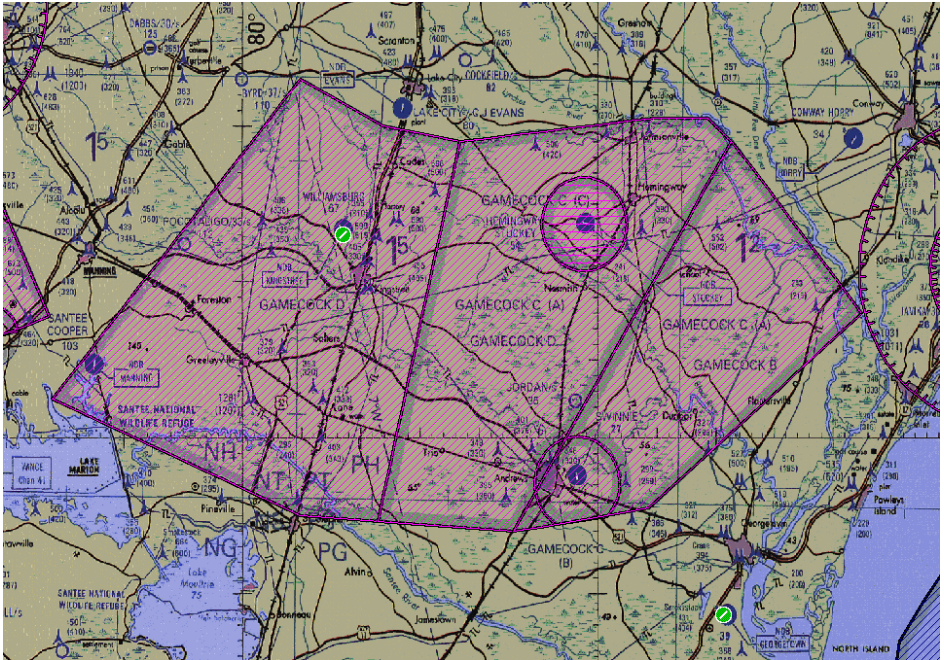

Figure 10: Top View of Gamecock B, C, D, and Robroy MOAs

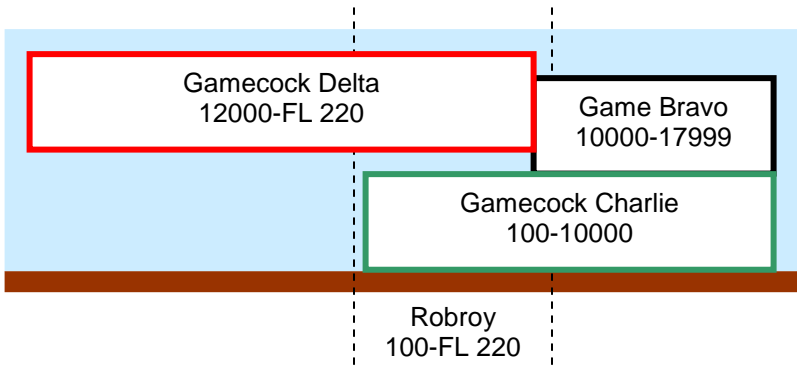

Figure 11: Side View of Gamecock B, C, D, and Robroy MOAs

BULLDOG A/B/C/D/E MOAs: Another Special Use Airspace frequently used is the Bulldog MOA structure approximately 100 NM southwest of Shaw AFB.

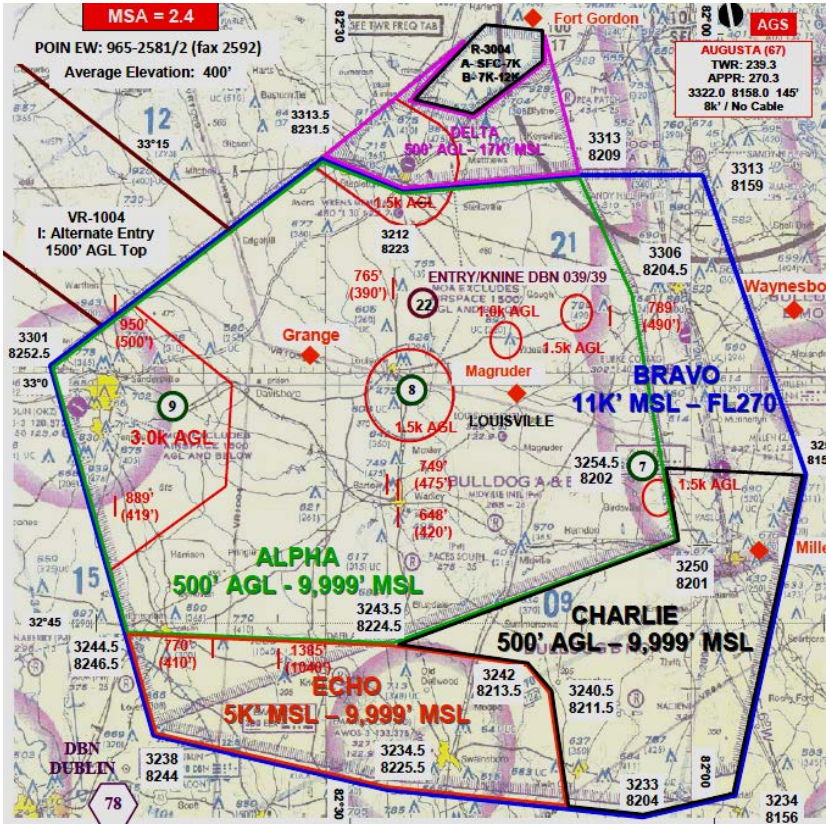

Figure 12: Top View of Bulldog A/B/C/D/E MOAs

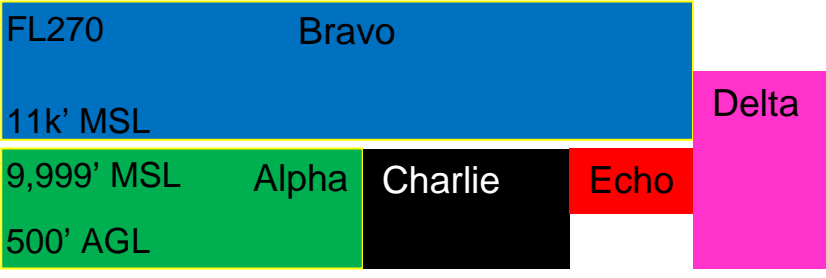

Figure 13: Side View of Bulldog A/B/C/D/E MOAs

GAMECOCK I MOA: An additional Gamecock MOA is located approximately 25 NM north of Shaw AFB.

GAMECOCK I MOA: 100 feet AGL up to 6,000 feet MSL

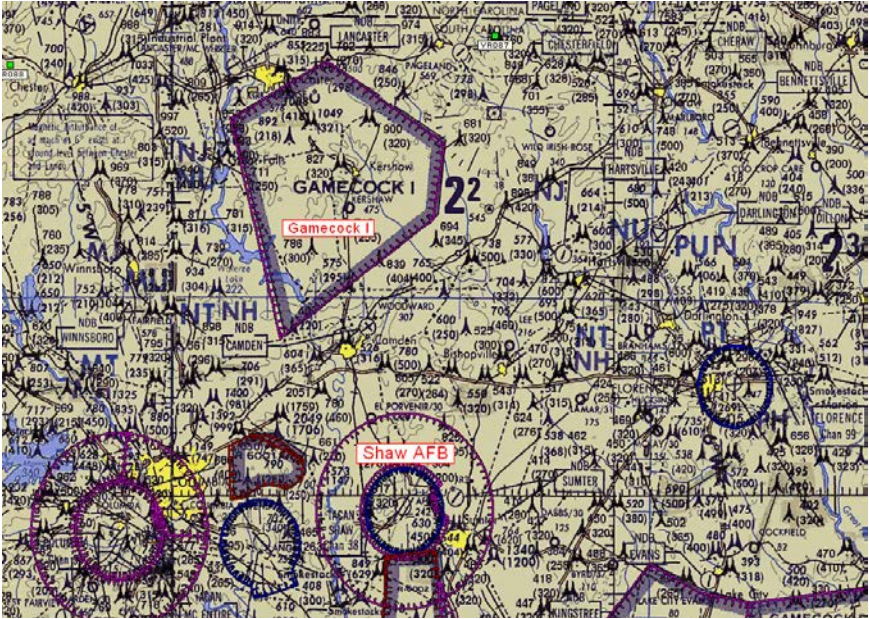

Figure 14: Top View of Gamecock I MOA

There is no FAA restriction preventing VFR aircraft from transiting an active MOA; however, we **strongly recommend** you avoid them whenever possible. Due to the high speed and dynamic flight profiles being flown by our military aircraft in the MOAs, there is limited opportunity to locate and avoid VFR aircraft. If you must fly through an active MOA we **strongly recommend** you maintain contact with the controlling ATC agency. If you do this it will allow the controllers to give you traffic advisories as well as advise the participating military aircraft of your presence.

At night, these MOAs are used for Night Vision Goggle (NVG) training. With NVGs, aircraft will potentially be using reduced lighting, which means that they will be even more difficult to visually acquire.

NOTE: MOAs are depicted on sectional charts with the applicable altitudes listed on the edge of the chart.

Military Training Routes: These low-level routes differ from MOAs because flight operations are point-to-point along a route of flight instead of in a defined area. Military training routes were established to accommodate low-level tactical and navigation training that may be conducted in excess of 250 knots below 10,000 feet MSL. Routes are marked on sectional charts and may be used during the day and at night. The markings of routes on VFR sectional charts show only the route centerline; the routes are normally between 8 – 20 miles in width. They also have varying altitude blocks that may be from 100 feet AGL up to 10,000 feet MSL.

Figure 15 shows the centerlines of several low level routes in the vicinity of Shaw AFB. These routes include VR-087, VR-088, VR-097, VR-1059, IR-035, and IR-036. These routes are also depicted on VFR sectional charts.

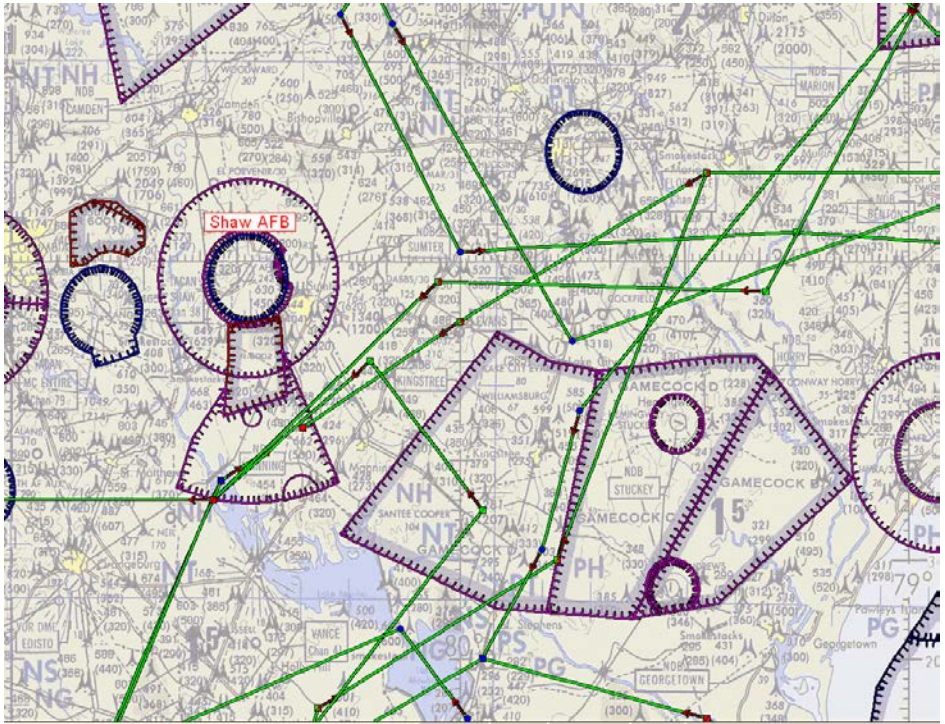

Figure 15: Military Training Routes

SECTION 3 ----- CONTROLLED AIRSPACE

Shaw Air Force Base Class C Airspace: This is airspace established around Shaw AFB. Basic requirements to enter this airspace are: Two-way radio communications with Shaw Approach Control (RAPCON) and an operable transponder.

Two way radio communications with Shaw Approach Control is required **prior** to entering Shaw's Class C airspace. See Aeronautical Information Manual for further information and requirements.

Dimensions of Shaw Air Force Base Class C Airspace

Airspace	Dimensions	Altitudes
Surface Area/ Inner Core	5 NM with 2 NM cutout centered on Sumter Muni	Surface to 4,200' MSL (4,000' AGL)
Outer Circle	5 NM to 10 NM	1,500' MSL to 4,200' MSL
Outer Area	20 NM Radius of Shaw AFB	Lower limits of radio/radar coverage to 10,000' MSL

SSC Class "C" Airspace

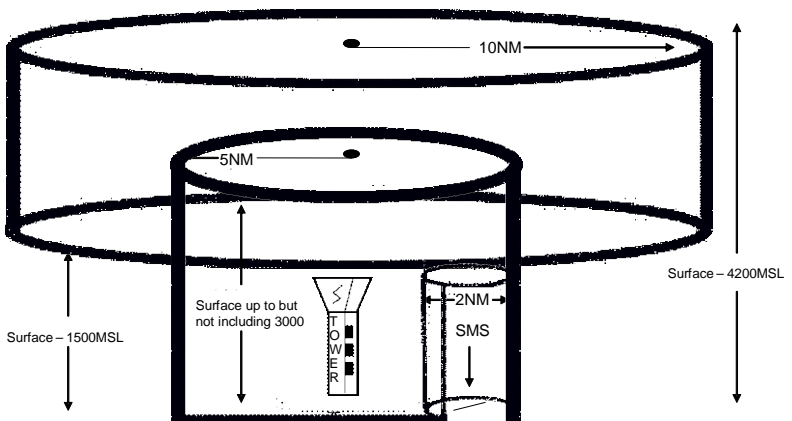

2.1.3. Class C Airspace. Shaw Class C is defined in FAAO 7400.9. When the RAPCON is closed, the tower airspace reverts to Class D as defined in FAAO 7400.9. RAPCON delegates to the tower the airspace surface up to but not including 3,000 feet MSL within a 5 nautical mile radius of Shaw AFB excluding that airspace extending upward from 1,500 feet MSL within a 2-mile radius of Sumter Municipal Airport. This airspace is designated as the Shaw Class —C1 Surface Area. When the ceiling is reported as less than 1000' feet and/or the visibility is less than 3 miles, RAPCON retains control of the Shaw Class C surface area.

Reference: SAFBI 11-250, paragraph 1.9.1

Figure 16. Shaw AFB Class C Airspace

NOTE 1: Surface Area and Outer Circle are regulatory – Contact with Shaw Approach Control is required. Shaw’s Outer Area is optional – If you choose to contact ATC you will be provided Class C services unless the controller is unable to provide the service (e.g., radar is out of service).

NOTE 2: While the Class C airspace contains most of the unusual operations associated with the base’s flying operations, some operations involving high rates of climb or descent cannot be contained within this airspace. This emphasizes the need for constant vigilance while operating in the area surrounding Shaw AFB. Shaw RAPCON is available for traffic advisories when transiting these areas. **The frequency to use is 125.4.**

NOTE 3: If you have any questions about Class C procedures, feel free to contact the RAPCON Chief Controller at 803-895-1058 for information and/or advice.

NOTE 4: Departures from Sumter Municipal Airport should remain clear of Shaw Class C airspace, until contact radio and radar contact is established with Shaw Approach Control on 125.4.

McEntire JNGB Class D Airspace: Class D Airspace is airspace tailored to contain operations within the local area of a tower controlled airport. General requirements are: Two-way radio contact with the McEntire control tower **prior** to entering the airspace and maintaining this contact while in the airspace.

Dimensions of McEntire JNGB Class D Airspace:

Airspace	Dimensions	Altitudes	Tower Freq
McEntire JNGB Class D	4.5 NM radius centered on McEntire JNGB	Surface to 2,800’ MSL	132.4

NOTE: Separation services are not provided by Air Traffic Control towers providing Class D services.

McEntire Ground Controlled Approach (GCA): Within approximately 15 NM south and southeast of McEntire JNGB from surface to 2000’ MSL. The GCA operates part time and will provide ATC radar services when available.

Airspace	Dimensions	Altitudes	GCA Freq
McEntire JNGB GCA	Approx. 15 NM south and southeast of McEntire	Surface to 2,000’ MSL	148.925

SECTION 4 ----- MILITARY AIRCRAFT IN LOCAL AREA:

F-16 Fighting Falcon: The F-16 is the U.S. Air Force's primary fighter/bomber. It is capable of being used in a number of combat roles on a global basis. There are three squadrons based at Shaw AFB and one squadron based at McEntire JNGB.



Departure: Normal departures will be at 350 KIAS, and climb rate is in excess of 6,000' per minute. Aircraft may or may not level off prior to 10,000' MSL.

Arrival: Airspeed on arrivals will normally be 300 KIAS for operations under 10,000' MSL. When in the traffic pattern the following speeds are normal:

Initial/Overhead Recovery	300 KIAS
Downwind (Radar Pattern)	250 KIAS
Final Approach	160 KIAS

Unusual Operations:

Simulated Flame-Out (SFO) Recovery: These are procedures to practice the recovery of an F-16 with a simulated engine failure (the F-16 is a single-engine fighter). During this recovery the aircraft may be directly over the runway at an altitude up to 9,500' MSL. During an overhead SFO, the aircraft will spiral down in idle power at approximately 220 to 230 knots and typically remain within 3 NM of the airfield. A straight-in SFO allows for the aircraft to start at 10 NM on final at 10,000' MSL and make a controlled descent with idle power to the runway. During these procedures the aircraft may be in a pitch attitude that will restrict visibility below and forward of the aircraft. While these maneuvers are in progress Shaw RAPCON will provide vectors to keep you clear of the area for the safety of all involved.

Airspace Control Alert: McEntire JNGB is tasked with alert missions. When F-16's are scrambled they may launch with speeds well in excess of 250 knots below 10,000' MSL. Potential for a scramble exists at all times regardless of tower status. Remain vigilant especially when operating near McEntire JNGB arrival and departure corridors.

WARNING: The major threat from the F-16 is its small size (32' wingspan/ 49' length) combined with its high speed. We normally fly in formation flights of two or more so if you see one, look for others!

Typical Fighter Formations

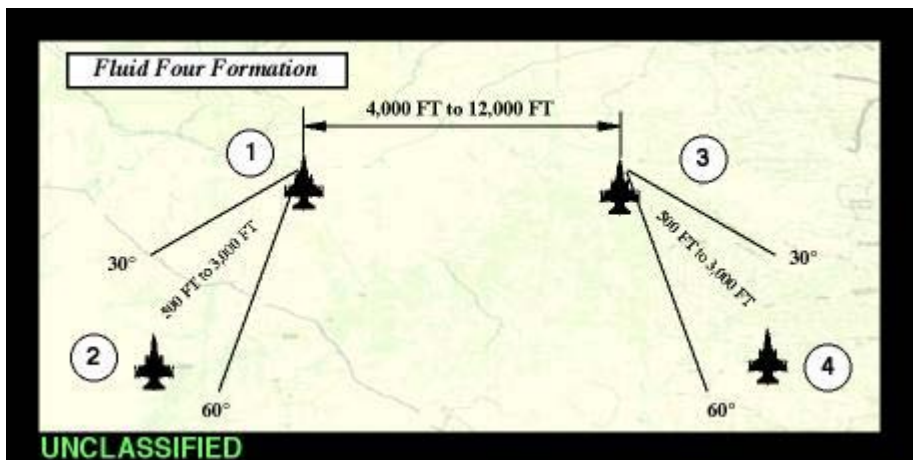
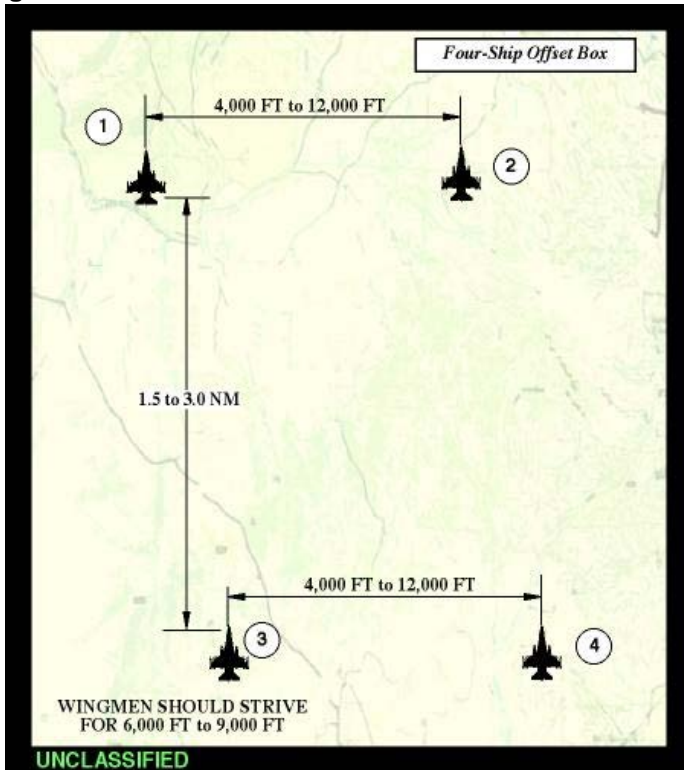

Figure 17: Typical Fighter Formations

A-10 Thunderbolt II: The A-10 is the U.S. Air Force's primary Close Air Support aircraft. A-10s from Moody AFB, GA, frequently fly in the local area.

Departure: 200 knots will normally be used for departure, and climb rate will be approximately 2,500' per minute. These aircraft will perform most flights under VFR flight rules. They may operate low-level in areas not coincidental with low level routes.



Arrival: Airspeed on arrivals will normally be 300 KIAS for operations under 10,000' MSL. When in the traffic pattern the following speeds are normal:

Initial/Overhead Recovery	300 KIAS
Downwind (Radar Pattern)	250 KIAS
Final Approach	140 KIAS

NOTE: While these aircraft are no longer stationed at Shaw AFB, they continue to use Poinsett Range and the local MOAs.

C-17 Globemaster: These are large cargo aircraft used for a wide variety of missions. They may be seen in the local area flying low level routes such as IR-35 and IR-36, as well as flying high altitude operations. They also conduct takeoff, landing, and paradrop operations at North Auxiliary airfield near Orangeburg, SC. Operations within the low-level route structure are normally conducted at 300-350 KIAS at an altitude from 300' AGL to 4,000' MSL. They may operate singly or in formations of two or more aircraft.



NOTE: These aircraft are classified in the "Heavy" weight class. They can cause wake turbulence/wing vortices that can upset other aircraft. You should remain vigilant and avoid areas below and behind these aircraft.



Helicopters: McEntire JNGB has, in addition to their F-16s, the following helicopters assigned to the Army National Guard: UH-72, BO-6 (formerly OH-58), AH-64, CH-47, and UH-60. These helicopters may be seen throughout the local area but fly mostly northeast of McEntire JNGB at altitudes below 2000' MSL. Helicopters may operate at any time regardless of tower status.



Various other military aircraft frequently use the airspace and ranges around Shaw AFB. It is common to see U.S. Navy and Marine Corps aircraft, such as F-18s, in this area. We emphasize again that in any high density traffic environment, you must always practice “see and avoid” and use good common sense while all of us *Share the South Carolina Skies!*

Sumter Model Airplane Club



Figure 18: Sumter Model Airplane Club

The Sumter Model Airplane Club is located to the southeast of Shaw AFB, in an open field across Hwy 76/378. Their model airplanes generally have wingspans of 50-60 inches; however, some model planes are slightly larger. They operate from the surface to 400' AGL, mostly on weekends.

Phone Numbers

Shaw Air Force Base

MACA Program Manager	803-895-1122
20th Fighter Wing Flight Safety Office	803-895-1971
Shaw Approach Control (Chief Controller)	803-895-1058
Shaw Tower	803-895-2624

Joint Base Charleston

437 Airlift Wing Flight Safety Office	843-963-5600/01/02
Charleston TRACON (FAA)	843-414-2808

McEntire Joint National Guard Base

169th Fighter Group Flight Safety Office	803-647-8218
McEntire Air Traffic Control	803-647-8272
McEntire Airfield Operations	803-647-8231

Frequency Information

<u>Shaw AFB</u>	
Shaw Approach	125.4
Shaw Tower	126.65
<u>McEntire JNGB</u>	
McEntire Tower	132.4
McEntire GCA/RAPCON	148.925
<u>Joint Base Charleston</u>	
Charleston Approach East	135.8
Charleston Approach West	120.7
Charleston Tower	126.0
<u>MOA Information</u>	
Poinsett Low MOA	133.25 (Shaw Approach)
Gamecock I MOA	125.4 (Shaw Approach)
Gamecock C MOA	127.4 (Myrtle Beach Approach)
<u>North Aux Airfield</u>	
Tower	118.15

Customer Service Questionnaire

Aircraft ID: _____; Date/Time: _____

Acft Type: _____; Home Base: _____; Facility Rated: _____

Type of Pilot Certificate (circle one): PPL COMM INST ATP MIL

Type of Flight (circle one): VFR SVFR IFR

Please rate ATC service by circling the appropriate response:

1-Unsatisfactory; 2-Marginal; 3-Satisfactory; 4-Excellent; 5-Outstanding

ATC Delays	YES	NO			
Sequencing/Spacing	1	2	3	4	5
Advisory Service (timely, accurate, helpful)					
Traffic	1	2	3	4	5
Weather	1	2	3	4	5
Airfield	1	2	3	4	5
Control Instructions/Information					
Approach Clearance	1	2	3	4	5
Vectors	1	2	3	4	5
Holding Instructions	1	2	3	4	5
IFR Clearances	1	2	3	4	5
Emergency Assistance (responsiveness/effectiveness)					
	1	2	3	4	5
Instrument Approach Procedures	1	2	3	4	5
ATC Radios/Communications	1	2	3	4	5
ATC Attitude/Professionalism	1	2	3	4	5
Overall Rating	1	2	3	4	5

Comments/Suggestions: _____

Thank you for your feedback. Please return this sheet to the MACA Program Manager, 428 Killian Ave, 20 OSS/OSOA, Shaw AFB, SC 29152-5041

<http://www.shaw.af.mil/library/maca/index.asp>